



US 20100276119A1

(19) **United States**

(12) **Patent Application Publication**
Doty

(10) **Pub. No.: US 2010/0276119 A1**

(43) **Pub. Date: Nov. 4, 2010**

(54) **COMPACT, HIGH-EFFECTIVENESS,
GAS-TO-GAS COMPOUND RECUPERATOR
WITH LIQUID INTERMEDIARY**

Related U.S. Application Data

(60) Provisional application No. 61/016,247, filed on Dec. 21, 2007, provisional application No. 61/034,148, filed on Mar. 5, 2008.

(75) Inventor: **F. David Doty**, Columbia, SC (US)

Publication Classification

Correspondence Address:
Oppedahl Patent Law Firm LLC
P O Box 5940
Dillon, CO 80435-5940 (US)

(51) **Int. Cl.**
F28D 15/00 (2006.01)
F28D 1/04 (2006.01)
F28F 1/28 (2006.01)

(52) **U.S. Cl.** **165/104.31; 165/157; 165/182**

(57) **ABSTRACT**

(73) Assignee: **DOTY SCIENTIFIC, INC.**,
Columbia, SC (US)

A liquid-loop compound recuperator is disclosed for high-ε heat exchange between a first shell-side fluid stream and a second shell-side fluid stream of similar thermal capacity rates (W/K). The compound recuperator is comprised of at least two fluid-to-liquid (FL) recuperator modules for transfer of heat from a shell-side fluid, usually a gas, to an intermediary tube-side heat transfer liquid (HTL). Each FL module includes a plurality of thermally isolated, serially connected, adjacent exchanger cores inside a pressure vessel. The cores are rows of finned tubes for cross-flow transfer of heat, and they are arranged in series to effectively achieve counterflow exchange between the HTL and the shell-side stream. The HTL may be water, an organic liquid, a molten alloy, or a molten salt.

(21) Appl. No.: **12/673,974**

(22) PCT Filed: **Jun. 13, 2008**

(86) PCT No.: **PCT/US2008/067008**

§ 371 (c)(1),
(2), (4) Date: **Feb. 19, 2010**

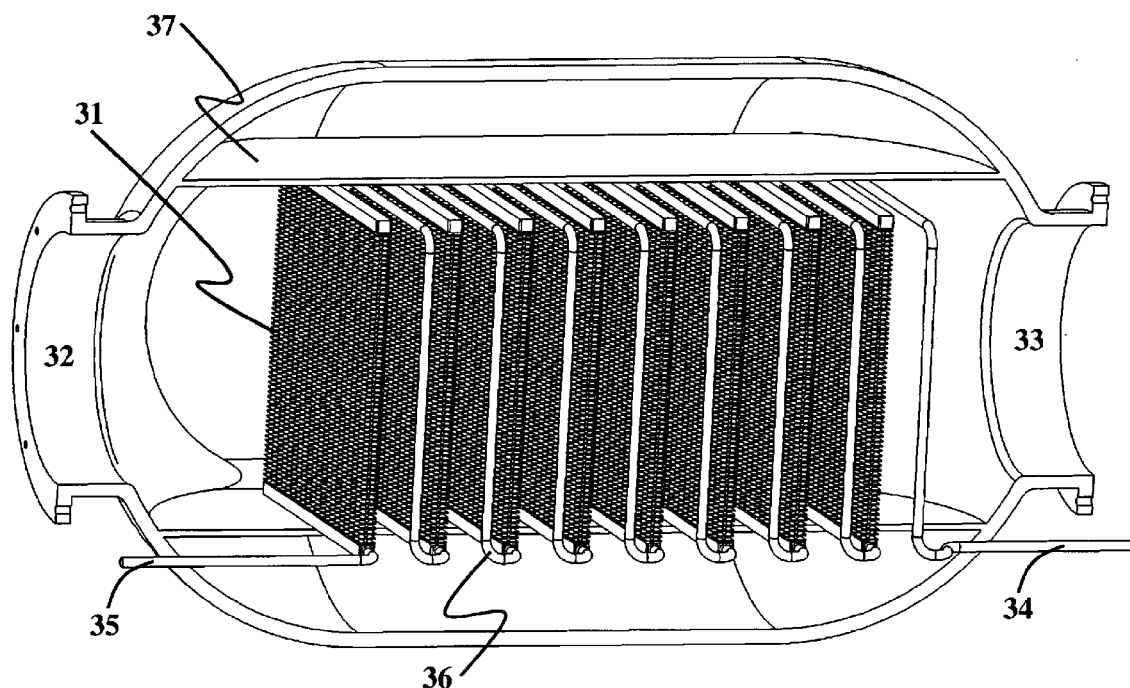

Figure 1

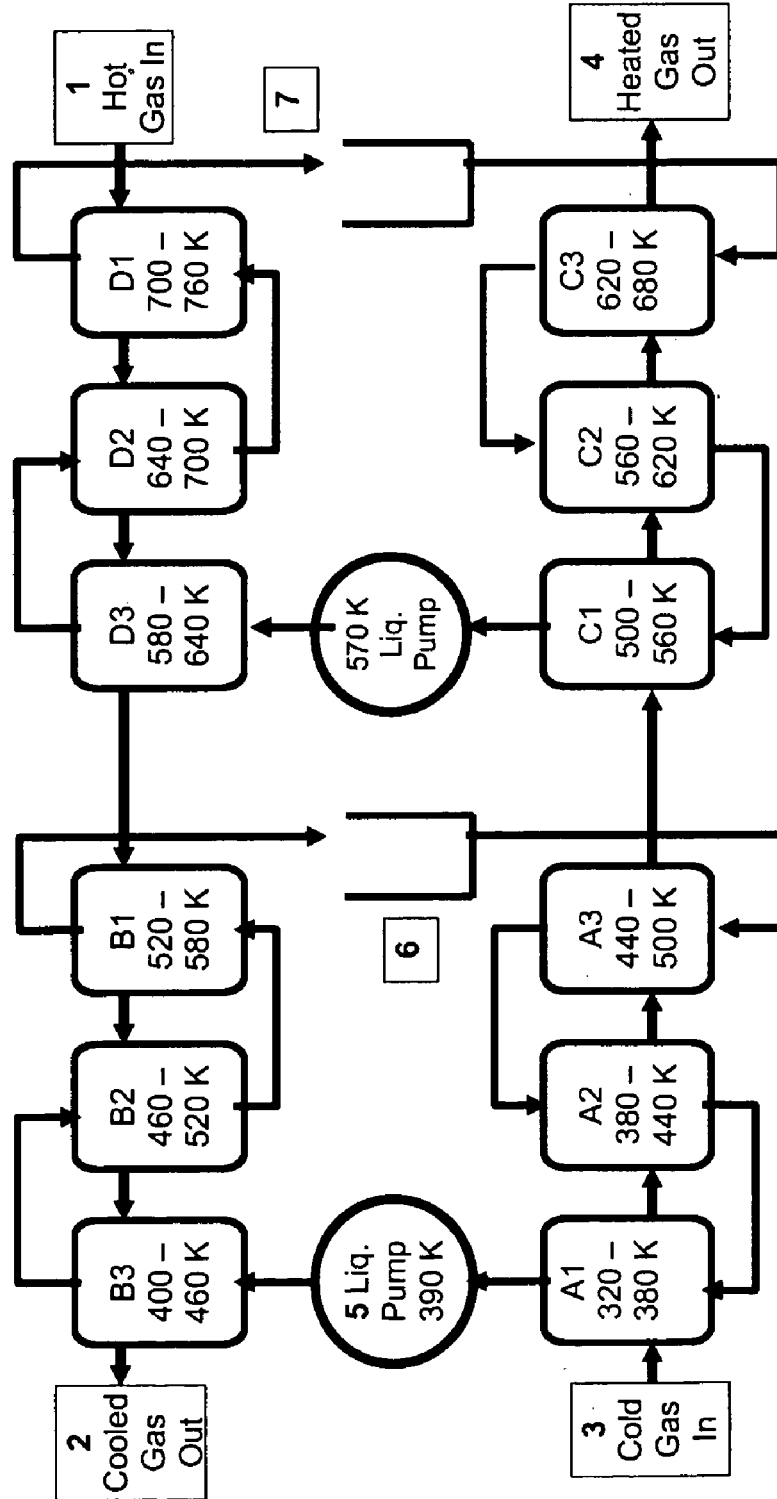
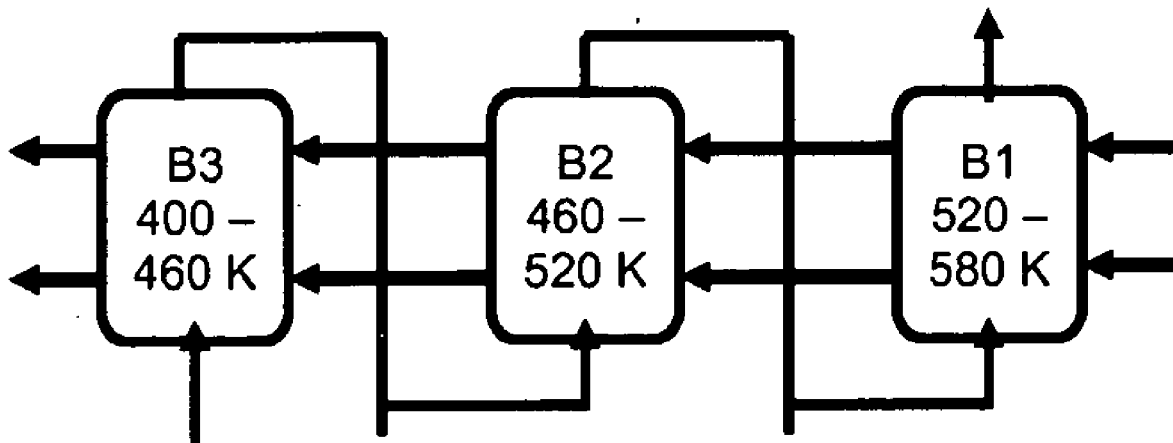

Figure 2



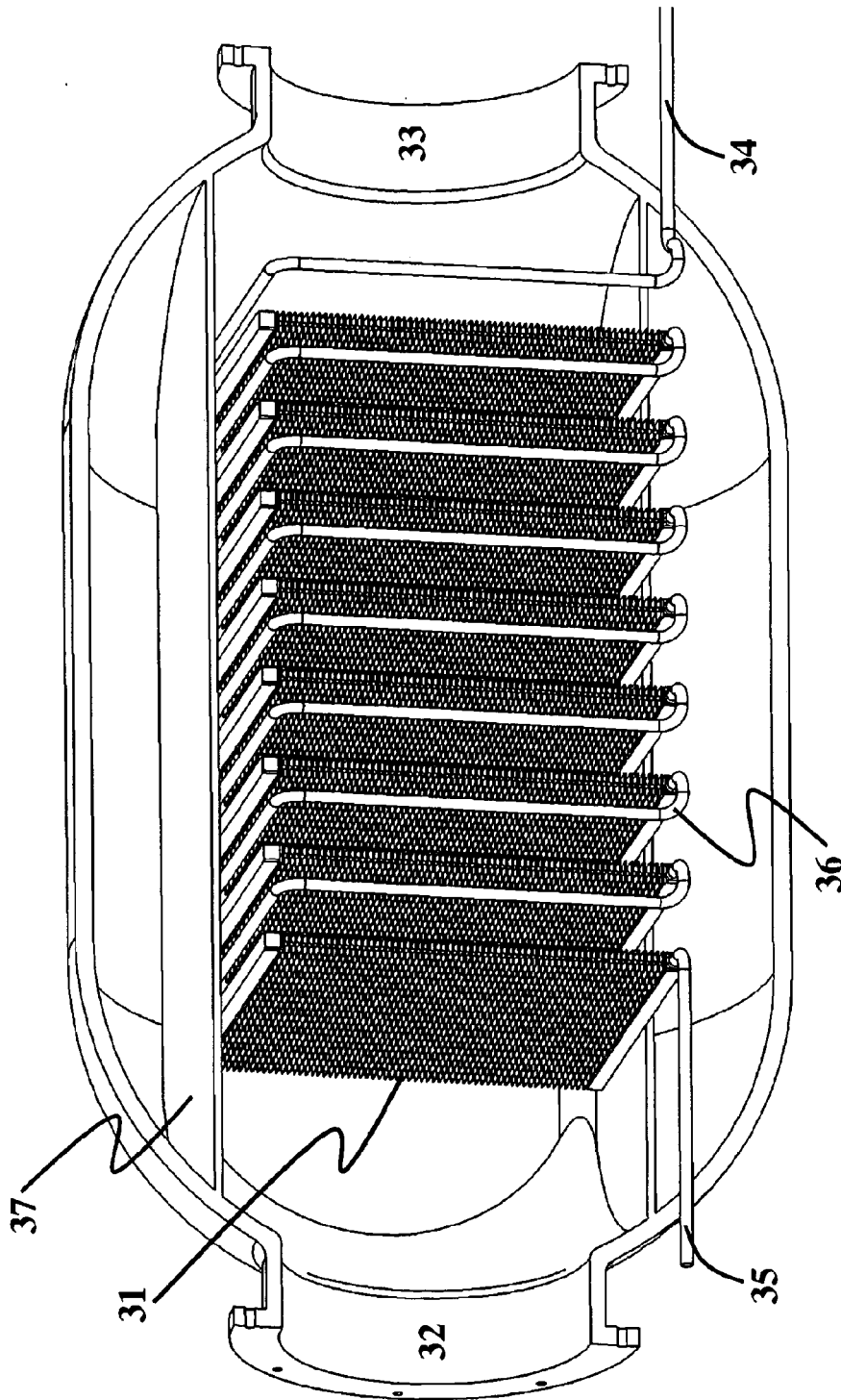

Figure 3

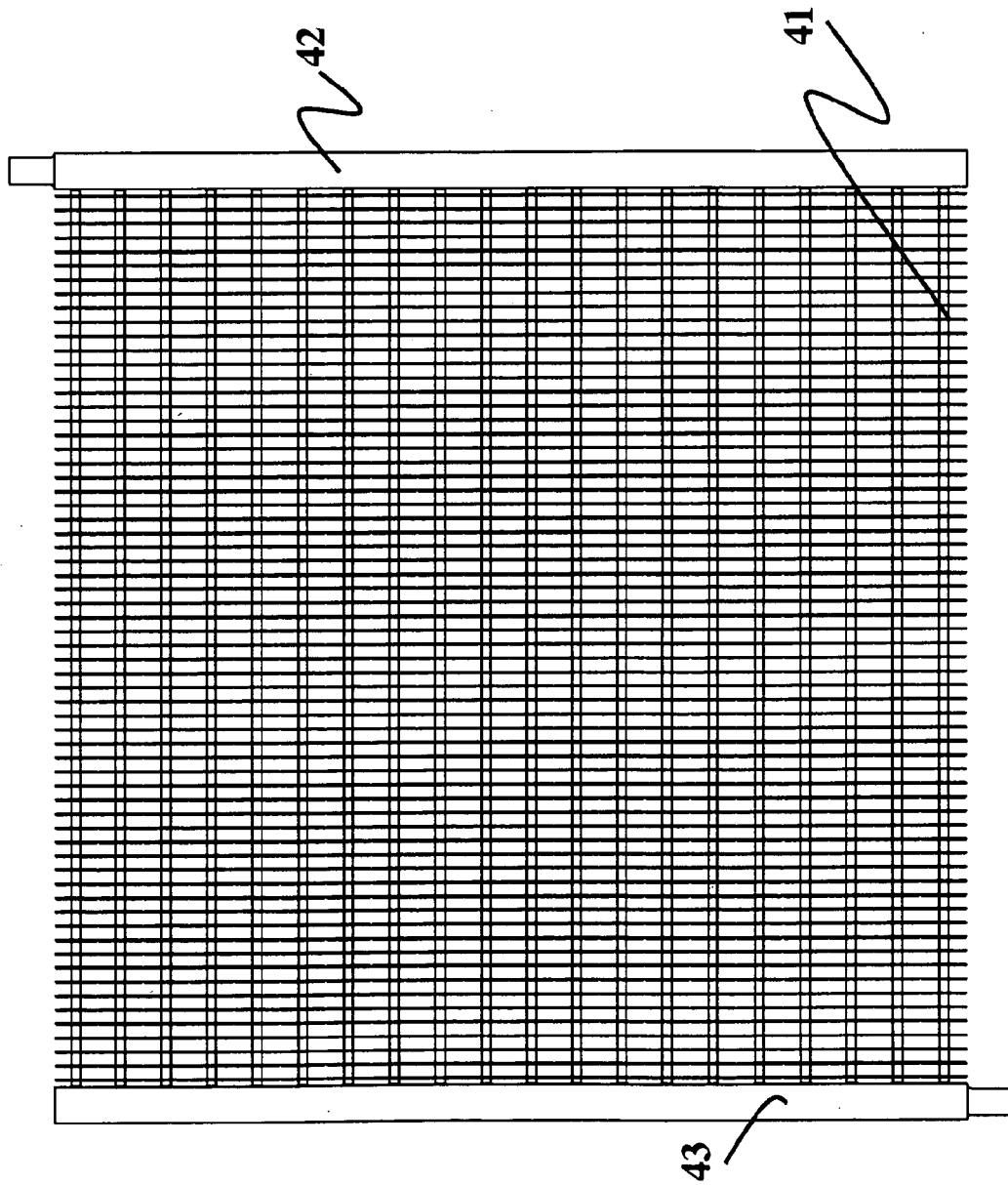

Figure 4

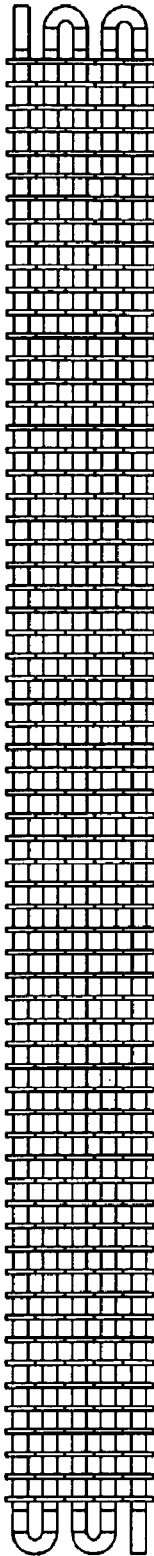

Figure 5

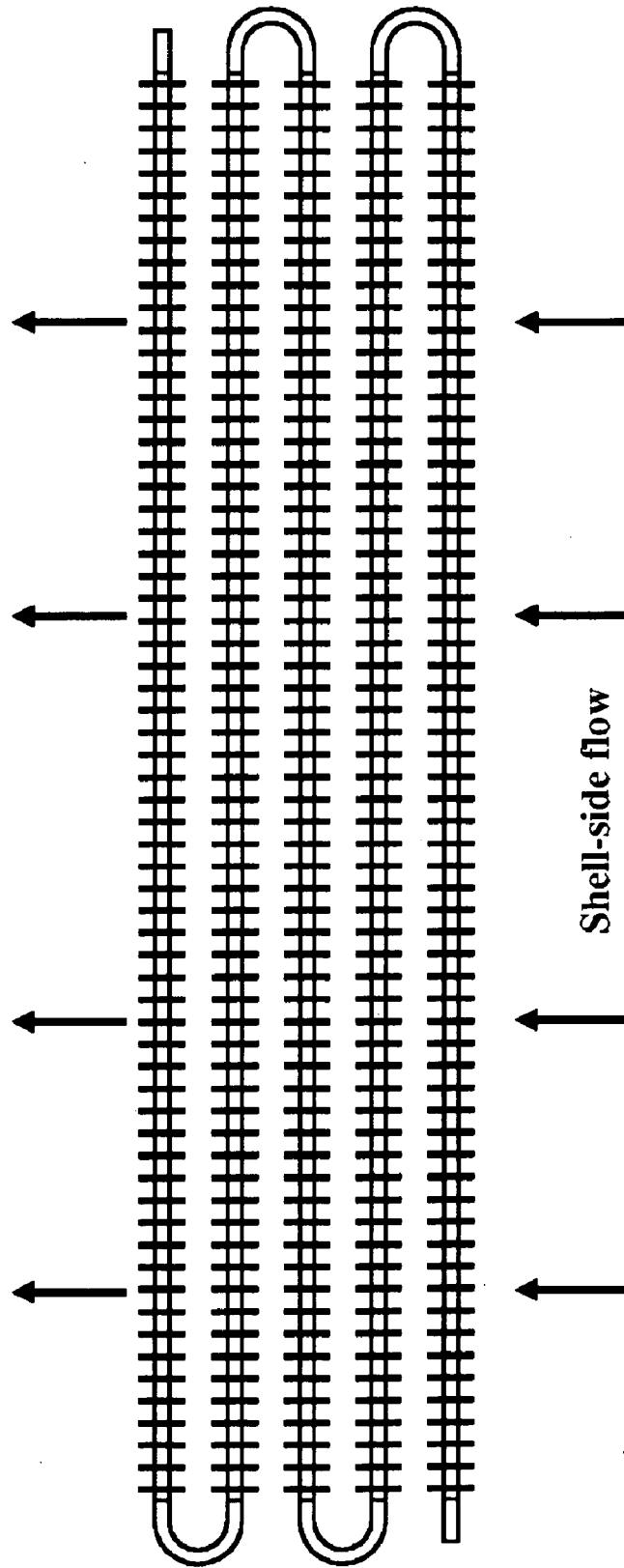

Figure 6

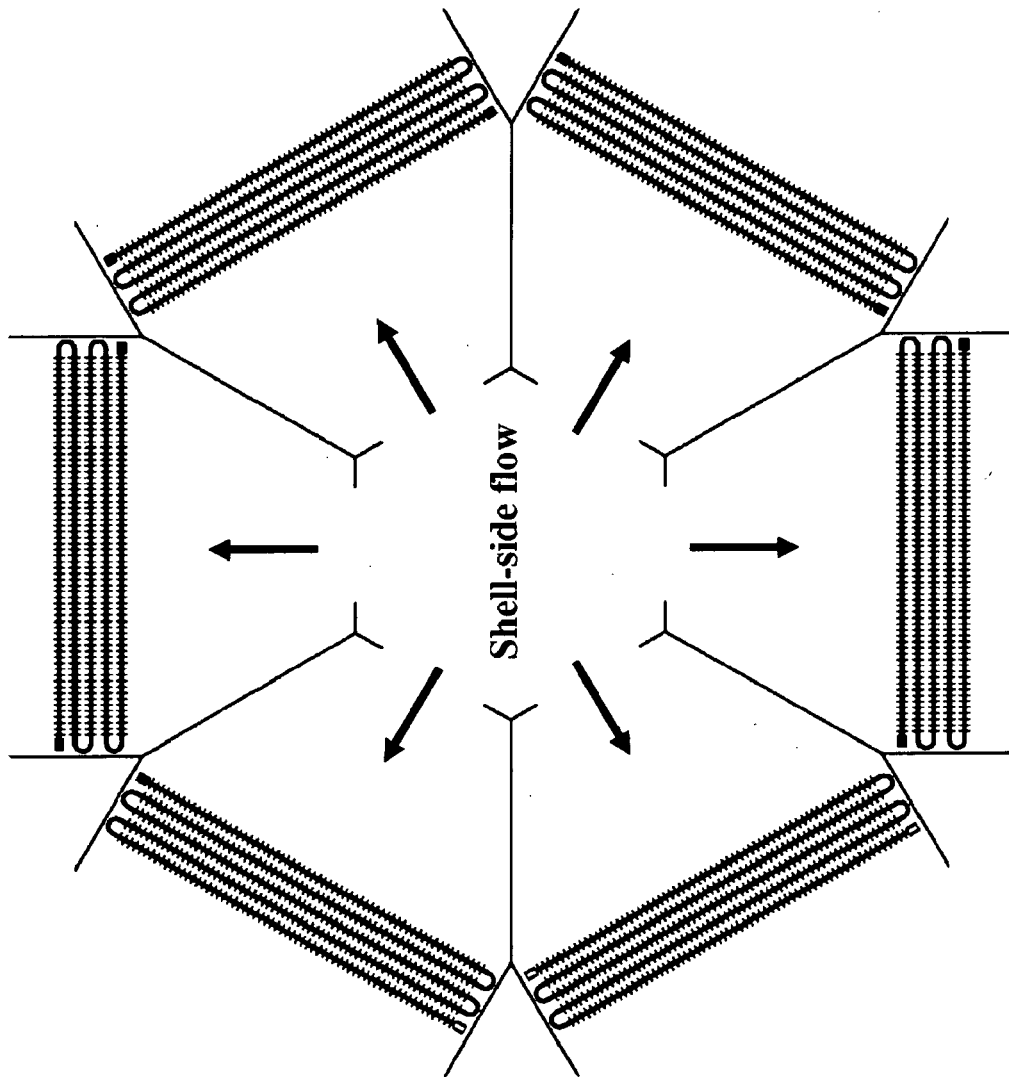

Figure 7

**COMPACT, HIGH-EFFECTIVENESS,
GAS-TO-GAS COMPOUND RECUPERATOR
WITH LIQUID INTERMEDIARY**

CROSS-REFERENCE TO RELATED
APPLICATIONS

[0001] This application claims the benefit of U.S. application No. 61/016,247 filed Dec. 21, 2007, and the benefit of U.S. application No. 61/034,148 filed Mar. 5, 2008, each of which is incorporated herein by reference for all purposes.

FIELD OF THE INVENTION

[0002] The field of this invention is heat exchangers, and more particularly, compact, gas-to-gas recuperation at high effectiveness for clean gases of similar heat capacity rates using compound recuperators with liquid intermediary.

BACKGROUND OF THE INVENTION

[0003] Gas-to-gas recuperation with both high thermal effectiveness and order-of-magnitude improvement in cost effectiveness is critical to addressing global energy needs, as shown in at least two co-pending patent applications. From a manufacturing perspective, the challenges arise from the fact that it is not practical to produce heat exchangers with closely-spaced fins on both the inside and outside of tubes, and alternative approaches thus far have had limited success.

[0004] An enormous number of heat exchangers have been well optimized for numerous purposes over the past four decades. However, most have not been directed at high thermal effectiveness ϵ for cases where the heat capacity rates in the two streams are similar. The heat capacity rate W of a stream is given by GC_p (its SI units are W/K), where G is the mass flow rate (kg/s) and C_p is the specific heat (J/kg-K). By the standard definition of ϵ (the ratio of heat transferred to the theoretical limit), high ϵ is most easily achieved when W_{min} (that of the weaker stream) is much less than W_{max} (that of the stronger stream). However, exergy destruction can be minimized only if W_{min} is close to W_{max} . The terms "recuperator" and "regenerator" have usually implied the streams have similar W 's, and that will be the usage and regime of primary focus in this invention. However, the streams need not be in the same state—one may be liquid while one is a gas.

[0005] Common examples of cost-effective heat exchangers with high exergy loss include automobile radiators and air-conditioning condensers. In the automobile radiator, for example, the warmed air leaves at a temperature much below that at which the hot water enters. Thus, most of the water's exergy (energy availability) has been destroyed, irrespective of precisely how one chooses to define it. Other examples of cost-effective compact exchangers for unrelated purposes include micro-channel, compact, fluid cooling systems, as seen for example in U.S. Pat. No. 6,907,921.

[0006] The subset of fluid heat exchangers directed at high ϵ have mostly addressed one of the following cases: condensing-vapor-to-liquid, condensing-vapor-to-gas, boiling-liquid-to-liquid, boiling-liquid-to-gas, liquid-to-gas, or liquid-to-liquid. In all of these cases, the fluid thermal conductivities, k_p W/m-K, are fairly large on at least one side (generally over 0.2 W/m-K), or phase change is present to drive small-scale turbulence on one side. A common gas-to-gas exchange application is in steam power-plant superheaters. However, the steam here has high thermal conductivity and rather high density (for example, 0.067 W/m-K and 40

kg/m³ at 10 MPa, 650 K). Moreover, high ϵ there is not an objective, as the flue gas will be used subsequently for boiling. Gas-to-gas exchange is also sometimes seen in air preheaters in steam power plants. Here, moderately high ϵ may be seen, though usually the minimum flue-gas exhaust temperature is \sim 400 K to limit corrosion from acid condensation, and this limits ϵ of these recuperators:

[0007] Achieving high ϵ in gas-to-gas exchange with low pumping power has been challenging because volumetric specific heats are much lower than seen in liquids and thermal conductivities are usually low. Challenges are also seen in achieving high ϵ in recuperators for organic liquids just above their pour point where viscosity is quite high.

[0008] Doty, in U.S. Pat. No. 4,676,305, disclosed a compact method of achieving highly effective recuperation with low pressure drop for gases of similar W 's. However, this microtube recuperator has not yet been shown to be commercially competitive with the brazed plate-fin type, in wide usage in recuperated open Brayton cycles in the 30-250 kW range and occasionally up to 25 MW. See, for example, the microturbines available from Capstone Turbines Corporation, of Chatsworth, Calif. These too have limited cost effectiveness and limitations in accommodating applications where there are large pressure differences (greater than \sim 0.7 MPa) between the two streams at high temperatures (above \sim 750 K).

[0009] Optimized, compact high- ϵ gas-to-gas recuperators require low flow velocities (several percent of the sonic velocity), total flow-path exchange lengths in the range of 0.1 to 2 m, and passage hydraulic diameters of 0.5 to 8 mm, with the larger diameters corresponding to pressures near 0.1 MPa and the smaller sizes corresponding to pressures above 0.5 MPa. They have also required the use of construction materials having fairly low thermal conductivity, though that is not required in this invention.

[0010] An alternative to paralleling tens of thousands of microtubes that has seen rather little usage but appears to be the most competitive for some compact recuperation applications is the rotating honeycomb regenerator, as used in some turbine engines where system mass is critical. Oda et al in U.S. Pat. No. 4,304,585 disclose an early ceramic design. Regenerators have seen very little usage largely because of the difficulties in obtaining adequate isolation between the high-pressure and low-pressure streams and because of the shedding of ceramic particles, leading to turbine abrasion.

[0011] Ceramic is usually selected for honeycomb regenerators in recuperated aero-turbine applications because of the need for oxidation resistance at high temperatures and the advantage of low thermal conductivity in the flow direction. Rotating ceramic honeycomb regenerators have demonstrated ϵ above 98% while the brazed plate-fin recuperators seldom achieve more than 87% ϵ , primarily because of cost and mass optimization constraints. The honeycomb regenerators can be an order of magnitude more compact and an order of magnitude less costly for a given exchange power and ϵ than plate-fin microturbine recuperators—which are an order of magnitude more compact than the gas-to-gas exchangers seen in most current chemical engineering and power generation applications.

[0012] Oxidation resistance is irrelevant in some applications, and there honeycomb regenerators can be made at lower cost and with much higher reliability from a low-conductivity alloy honeycomb, such as silicon bronze, stainless steel, or some magnesium or aluminum alloys. The thermal

conductivity of silicon-nickel-bronze can be below 40 W/m-K, and 120 W/m-K is sufficiently low except perhaps for the most compact applications. For example, a magnesium alloy with thermal conductivity ~ 90 W/m-K has been used experimentally in a helicopter turboshaft engine. Titanium alloys would be better, and their relative cost should decrease over the next decade. The much higher thermal stress tolerance of metals compared to ceramics is extremely beneficial with respect to durability, as thermal stress is a primary factor limiting ceramic regenerator design and contributing to shedding of particles from ceramic regenerators.

[0013] Regenerator cost for a given performance is typically near minimum when pore diameters are about 0.7 mm for many mobile gas-gas exchange applications. The relevant design theory, well understood for more than three decades, has recently been reviewed and updated by David G Wilson in "Design and Performance of a High-Temperature Regenerator Having Very High Effectiveness, Low Leakage and Negligible Seal Wear", paper GT 2006-90096, Turbo-Expo 2006. The use of a metal for the honeycomb, possibly with the innovations in Wilson's U.S. Pat. No. 5,259,444, may permit a satisfactory solution of the sealing and wear problems in larger recuperators where the pressure difference between the two streams is small.

[0014] However, the rotating honeycomb regenerator still has substantial limitations, either where there are substantial pressure differences between the two streams, or where the size is small (below ~ 100 kW), or where the lower-pressure stream is above ~ 0.4 MPa. This last condition leads to greater difficulties in limiting leakage and carry over, and it leads to unreasonably low porosity requirements (or high solidity) in the honeycomb (for sufficient thermal storage). High solidity exacerbates axial thermal conduction losses and makes the regenerator more massive and perhaps more prone to stress-related failure. When two or more of the above conditions are present simultaneously, the honeycomb suffers markedly.

[0015] High- ϵ recuperators are essential in many cryogenic processes. A common and extremely effective design in cryocoolers uses micro-multi-port (MMP) tubing with one of the gases flowing in one direction through some of the "ports" (passages) and the other flowing in the opposite direction through the other ports. The viscous losses in very long lengths (4-20 m) of microtubes (under 1 mm ID, inside diameter) are often fully acceptable for gases at very high pressures (over 1 MPa) and low temperatures (below 140 K). Many cryogenic recuperators operate at such conditions, where outstanding counterflow recuperators can be made from MMP tubing or a similar construction. For many cryogenic applications outside the above conditions, the novel compound recuperator presented herein will be superior.

[0016] The basis for the innovation presented herein begins by learning from the highly developed liquid-to-gas exchangers best exemplified in air-conditioning (AC) condensers and automobile radiators. To achieve the high ϵ sometimes needed in gas-to-liquid recuperation, it is simply necessary to arrange 5 to 30 of such exchangers in series, with the liquid flowing serially from the first to the last and the gas also flowing serially, but from the last to the first. Such a counterflow exchanger can be an order of magnitude less massive and less costly than conventional shell-and-tube gas-to-liquid counterflow exchangers of similar flow rates, pressure drops, and ϵ .

[0017] The dry-air condensers ubiquitous in AC condensers have been extremely well optimized by numerous air-

conditioning companies over the past four decades. For example, "80-ton" (280 kW of cooling) air conditioners are widely produced. The air-flow passage lengths in these condensers are often under 3 cm per row of tubes; and air-passages, though perhaps several centimeters wide, typically have thicknesses of ~ 1.5 mm. This corresponds to a hydraulic diameter of ~ 3 mm for the air flows, which interestingly is that predicted to be optimum at 0.1 MPa by the alternative analysis presented by Doty in U.S. Pat. No. 4,676,305. The condenser in such a unit typically rejects about 350 kW_T at a δT (dry air) of about 10° C. Some large commercial freezer systems utilize refrigerant R744, CO₂, where condenser pressures can exceed 6 MPa, so clearly high tube-side pressures can be accommodated by cross-finned tubes produced by automated manufacturing processes as used in AC condenser cores. These exchanger cores are usually intended for use with two-phase flow tube-side over a significant portion of their length. However, predominately single-phase tube-side liquid flow, as seen for example in U.S. Pat. No. 3,922,880 in a design for use in an AC unit, can also be very cost effective.

[0018] In U.S. Pat. No. 4,831,844 Kadle discloses that for condensing two-phase tube-side flow, substantial improvement is obtained by a step-down approach in which the tube-side vapor flow begins in two parallel tubes and then combines to a single tube about two-thirds of the way through the condensing process. Several advantages are noted for many AC applications, but the drawings therein also appear to show interleaved tube-side flow between parallel rows of finned tubes. Both step-down and interleaved tube-side flow would generally be disadvantageous for single-phase tube-side liquid flow in high- ϵ exchange, as addressed herein; but with such patterns avoided, common AC condenser cores may be utilized for high- ϵ recuperation.

[0019] Another common approach to improving tube-side heat transfer with a low-velocity liquid of low k_f is to use MMP tubing for the liquid-phase flow, as discussed by Guzowski et al (IMechE 1999, C543/083) and Guntly et al (U.S. Pat. No. 4,998,580). A simpler method is to insert turbulators, such as open-pitch coil springs inside the tubes. This can be quite beneficial with single-phase tube-side flow of liquids under certain conditions.

[0020] The solution for order-of-magnitude improvement (compared to shell-and-tube exchangers) in cost-effective high- ϵ recuperation between clean gases shell-side at moderate temperatures and liquids tube-side is to simply use a series arrangement of several AC condenser cores (of proper design), serially connected inside a pressure vessel. As seemingly obvious and advantageous as the above approach is for high- ϵ gas-liquid exchange, it does not appear to have been practiced as such—liquid-only tube-side flow through a series of thermally isolated cores. Related exchangers, in which the shell-side gas goes cross-wise back and forth several times over the length of cross-flow tubes, are commonplace; and often the tubes have fins (though usually spaced 3 to 15 mm). However, the above differences are of enormous importance with respect to manufacturing, compactness, and cost effectiveness.

[0021] Single- and multi-row cores similar to what are suitable for a component in the instant invention are produced by Armstrong under the product name Duralite™ Plate Fin Coils. But apparently the value of thermally isolated serially connected cores inside a pressure vessel has not previously been appreciated as optimum to achieve high- ϵ .

[0022] Perhaps series arrangements of thermally isolated cores similar to those used in AC condensers have not been considered for high- ϵ gas-liquid exchange because most large applications also require dealing with moisture, acids, and particulates in the gas stream. For many such cases, available shell-and-tube exchangers, developed primarily for condensing shell-side steam, with typical tube diameters of 12 to 50 mm and shell-side fins usually spaced ~ 6 mm, may be the best option, especially when the gas pressure is below 0.12 MPa and high ϵ is not desired.

[0023] The heat pipe is in some sense related to the compound exchanger disclosed herein, as it too uses an intermediary fluid. However, the heat pipe uses a self-pumped two-phase fluid tube-side, and it is poorly suited to gas-gas recuperation. So the relationship to the heat pipe is tenuous at best. A complex, finned, device cooler shown in U.S. Pat. No. 7,296,619 may incorporate heat pipes, though that document tries to distort and confuse the standard meaning of "heat pipe". Regenerators are also somewhat related, as they utilize an intermediary, but there it is a solid.

[0024] The standard air conditioner is most closely related to the inventive compound recuperator, as it too provides heat transfer between two gases using a fluid intermediary. There, however, the large majority of the heat transfer in each exchanger includes phase change, and a very energy-intensive vapor pump is required. It is possible that some air-to-air recuperators for heat recovery in buildings have utilized proprietary concepts somewhat related to those presented herein, but apparently all such have relied upon phase change in the fluid intermediary for most of the heat transfer, and there is no evidence that they have achieved high ϵ .

[0025] Tube-side phase change has previously been desired because it greatly increases tube-side heat transfer coefficient, h , W/m^2-K , and thus generally allows significant reduction in exchanger size. However, phase change is not desired in the instant invention, as it makes minimization of irreversibilities impractical (because it requires a very large number of intermediary loops). The instant invention allows for enormous reduction in exchanger size without phase change, and thus it also readily permits high ϵ . Not surprisingly, commonly used "refrigerants" are the worst type of fluids that can be imagined for the applications envisaged by the instant invention.

[0026] It is noteworthy that the chemical engineering process simulation software we have evaluated is not capable of handling the case where a tube-side liquid stream is being heated by gas in a cross-flow finned-tube exchanger, as seen in the instant invention.

[0027] Two co-pending patent applications disclose enormous, emerging applications for high- ϵ low-cost recuperation between clean gases where good solutions are not currently available: (A) where the hot gas stream enters above 550 K and at more than 0.2 MPa, especially if the pressure difference between the streams exceeds 1 MPa, (B) where some liquid condensation or frosting can be expected in one or both of the gas streams, and (C) where both gases are at pressures below 1 MPa, the pressure difference exceeds 0.1 MPa, the temperatures are above 90 K, and cross-contamination must be avoided. There also appears to be an enormous, emerging application for high- ϵ low-cost recuperation between viscous organic liquids. The invention presented herein addresses these and many other situations most optimally.

[0028] The instant invention is, in practice, usually implemented as a minimum of two separate modules with one or more liquid intermediary loops between them. Naturally, each independent module is usable as a fluid-to-liquid recuperator, where the shell-side fluid is usually a gas but may be a viscous liquid of low thermal conductivity.

RELEVANT ART

- [0029]** 1. M M Guzowski, F F Kraft, H R McCarbery, J C Noveskey, "Alloy and Process Effects on Brazed Automotive Condenser Tubing", <http://www.ent.ohiou.edu/~kraft/VTMS4paper.pdf>, presented at IMechE 1999, C543/083.
- [0030]** 2. F D Doty, G Hosford, J B Spitzmesser, and J D Jones, "The Micro-Tube Strip Heat Exchanger", *Heat Transfer Engr.*, 12, 3, 31-41, 1991.
- [0031]** 3. D G Wilson and J Ballou, "Design and Performance of a High-Temperature Regenerator Having Very High Effectiveness, Low Leakage and Negligible Seal Wear", paper GT 2006-90096, Turbo-Expo 2006, Barcelona.
- [0032]** 4. Trane Product Literature, "Installation, Operation, Maintenance: Series R", [http://www.trane.com/web-cache/rf/rotary%20liquid%20chillers%20\(rlc\)/service/rtaa-svx01a-en_09012005.pdf](http://www.trane.com/web-cache/rf/rotary%20liquid%20chillers%20(rlc)/service/rtaa-svx01a-en_09012005.pdf), RTAA-SVX01A-EN, 2005.
- [0033]** 5. F P Incropera and D P Dewitt, "Introduction to Heat Transfer", Wiley, NY, 2002.
- [0034]** 6. R K Shah, A D Kraus, D Metzger, "Compact Heat Exchangers", Hemisphere Pub., NY, 1990.
- [0035]** 7. L R Rudnick, "Synthetics, Mineral Oils, and Bio-based Lubricants: Chemistry and Technology", CRC, Boca Raton, 2006.
- [0036]** 8. K Weissermel, H J Arpe, *Industrial Organic Chemistry*, 4th ed., Wiley, 2003.
- [0037]** 9. C H Bartholomew and R J Farrauto, *Industrial Catalytic Processes*, Wiley, 2006.
- [0038]** 10. E Prabhu, "Solar Trough Organic Rankine Electricity System (STORES)", NREL/SR-550-39433, <http://www.nrel.gov/docs/fy06osti/39433.pdf>, 2006.
- [0039]** 11. DESIGN II for Windows, Version 9.4, 2007, by WinSim Inc., documentation available from <http://www.lulu.com/includes/download.php?fCID=390777&fMID=810115>.
- [0040]** 12. Armstrong Duralite™ Plate Fin Coils, product information, Granby, Quebec, 2008, <http://www.armstronginternational.com/files/common/allproductscatalog/platefincoils.pdf>

U.S. PATENT DOCUMENTS

3,922,880	December 1975	Morris	62/498
3,994,337	November 1976	Asselman et al	165/119
4,304,585	December 1981	Oda et al	65/43
4,645,700	February 1987	Matsuhisa et al	428/116
4,676,305	June 1987	Doty	165/158
4,831,844	May 1989	Kadle	62/507
5,259,444	September 1993	Wilson	165/8
5,435,154	July 1995	Nishiguchi	62/476

-continued

U.S. PATENT DOCUMENTS			
6,907,921	June 2005	Insley	165/170
6,957,689	October 2005	Ambros et al	165/41
7,225,621	June 2006	Zimron et al	60/651
7,296,619	November 2007	Hegde	165/104.33

U.S. PATENT Application Publication		
US 2006/0211777	September 2006	Severinsky

SUMMARY OF THE INVENTION

[0041] A liquid-loop compound recuperator is disclosed for high-s heat exchange between a first shell-side fluid stream and a second shell-side fluid stream of similar thermal capacity rates (W/K). The compound recuperator is comprised of at least two fluid-to-liquid (FL) recuperator modules for transfer of heat from a shell-side fluid, usually a gas, to an intermediary tube-side heat transfer liquid (HTL). Each FL module includes a plurality of thermally isolated, serially connected, adjacent exchanger cores inside a pressure vessel. The cores are rows of finned tubes for cross-flow transfer of heat, and they are arranged in series to effectively achieve counterflow exchange between the HTL and the shell-side stream. The HTL may be water, an organic liquid, a molten alloy, or a molten salt. Alumina-dispersion-strengthened-metal fins, superalloy tubes, and a lead-bismuth-tin alloy HTL may be used for high temperatures. Cumene may be used as the HTL in cryogenic applications.

BRIEF DESCRIPTION OF THE DRAWINGS

[0042] FIG. 1 illustrates schematically a multi-stage, liquid-loop, compound recuperator.

[0043] FIG. 2 illustrates the preferred liquid routing for a portion of a compound exchanger.

[0044] FIG. 3 is a perspective, cut-away view of a typical fluid-liquid exchanger module.

[0045] FIG. 4 illustrates a typical, single-row, finned-tube core.

[0046] FIG. 5 illustrates a serpentine pattern in a finned-tube core.

[0047] FIG. 6 illustrates five thermally isolated series tubes.

[0048] FIG. 7 illustrates a radial-flow version of an FL module.

DETAILED DESCRIPTION OF THE PREFERRED EMBODIMENT

[0049] FIG. 1 illustrates a 4x3 array of 12 liquid-gas cross-flow exchanger cores with 2 liquid pumps and two different heat transfer liquids as an example of a method of achieving high-c recuperation between two isolated fluids of low thermal conductivity, gas-1 and gas-2, identified in the figure using hollow lines. These fluids have mean thermal conductivity less than 0.4 W/m-K (that of H₂ at ~720 K) and will usually be gases with k_f less than 0.06 W/m-K. Thus, for improved clarity, they are generally referred to as gases

herein, though applications where these fluid streams would be viscous organic liquids are seen in a co-pending patent application. Both gas-1 and gas-2 are shell-side, sometimes also called "fin-side". In this example, gas-1 is the hot source stream, and gas-2 is the cold stream being heated to nearly the entry temperature of gas-1. Often, the hotter gas will be at lower pressure than the cooler gas, but the reverse relationship is also possible.

[0050] In the example of FIG. 1, there are four sets of exchangers (A, B, C, D). The heat transfer liquids (HTLs) are identified in the figure with heavy solid lines. Here, each is directed serially through three cross-flow exchanger cores for each gas stream. The HTLs are all tube-side.

[0051] In this example, gas-1 enters 1 fin-side into exchanger labeled D1 at 760 K and exits 2 fin-side from exchanger B3 at 400 K. Gas-2 enters 3 fin-side into exchanger labeled A1 at 320 K and exits 4 fin-side from exchanger C3 at perhaps 680 K. For such temperatures with similar Ws, ϵ would be about 78% by the standard definition.

[0052] Here, each gas stream passes through 6 cross-flow exchanger cores, three on each side of each liquid loop. In practice, this will often be a minimum number, though it also depends on how one defines a cross-flow exchanger core. For example, a typical AC condenser "core" contains 2, 3, or 4 rows of finned tubes, often connected serially. Hence, a typical, 3-row, serial "AC core" could perform the three serial exchanges as shown in FIG. 1 for each side of each loop. Herein, 3 rows of thermally isolated finned tubes, serially connected, is considered to be three cross-flow exchanger cores in series. For the rows to be considered thermally isolated, it is required that the fin metal not be continuous from one row to the next (at least on most of the fins) and that the tube flow pattern not be interleaved—that is, that the tubes not return back to a first row after leaving that row and going to a second row. From a functional perspective, the rows may be considered to be thermally isolated if the thermal conduction of the metal between adjacent rows is less than twice the thermal conduction of the fluids (the sum of the shell-side and tube-side) between the rows.

[0053] For variety in presentation, a thermally isolated, serially connected, cross-flow exchanger core may be referred to as a "finned tube row". The complete serial group of tube rows in a single HTL loop for one of the gases will be referred to as a "core set". The core sets will be inside a pressure vessel to contain the shell-side pressure, and often all the sets associated with the first gas stream would be inside one pressure vessel, and those associated with the second gas stream would be inside a second pressure vessel. For example, sets B and D of FIG. 1 would normally be inside one pressure vessel and sets A and C would normally be inside a second pressure vessel. The pressure vessel with the cores it contains may be referred to as a fluid-to-liquid (FL) recuperator module or a gas-to-liquid (GL) recuperator module, as the shell-side fluid will usually be a gas.

[0054] The combination of two FL recuperator modules coupled with an intermediary HTL may be referred to as a liquid-loop recuperator or a compound recuperator. At least one liquid pump 5 and surge tank 6 are also required for each compound recuperator. FIG. 1 illustrates a dual-loop compound recuperator.

[0055] For minimization of 6T-related irreversibilities, the thermal capacity rate $W_L = G_L C_{PL}$ of the HTL through a core set in a compound recuperator should be close to the geomet-

ric mean W_s of the thermal capacity rates W_1 and W_2 for the two shell-side gas streams, $G_1 C_{P1}$, and $G_2 C_{P2}$,

$$W_L \sim W_S = (W_1 W_2)^{0.5}. \quad [1]$$

Moreover, the ratio W_1/W_2 should be fairly close to 1, though the compound recuperator will also be advantageous for other conditions. Normally, W_L would be between $0.7W_S$ and $1.4W_S$. Of course, G_L is proportional to $n\pi d^2 v$, where n is the number of parallel tubes in a core, ρ is the fluid density, v is the flow velocity, and d is the tube inside diameter (mm).

[0056] The practical ϵ limit (for similar W 's) is essentially determined by the total number of rows, n_r , of isolated, serially connected, finned tubes (or cores) and the "number of heat transfer units", NTU, where

$$NTU = h_{LS} A_X / W_S, \quad [2]$$

where A_X is the heat transfer surface area. The ϵ suggested for FIG. 1 is probably above a cost-effective limit for just 12 total cores with liquid intermediaries, though it is certainly possible. On the other hand, with 16 cores per set, four sets, and two liquid loops, a practical limit of about 94% would be expected. The same practical limit would be expected with a single liquid loop and 32 cores per set. Such a design would be preferred when the temperature difference between the hot source gas and the cold source gas is rather small, as this requires only one liquid pump. Having multiple loops, as shown in the multi-stage compound recuperator of FIG. 1, allows for the use of different HTLs in different temperature ranges, which allows for improved performance in large recuperators operating over a large temperature range.

[0057] FIG. 1, though drawn acceptably by diagramming conventions and chosen for its clarity, does not convey flow details that improve maximum practical effectiveness per tube row. The fluid routing shown in FIG. 2 better conveys liquid routing details that significantly improve effectiveness per stage. There, the liquid enters each row from the same side relative to the shell-side flow, which is always distributed across the face of the tube rows, as indicated by using parallel gas-flow arrows. The object is to make the direction of the thermal gradient along each row the same and maintain a fairly uniform change in the gas temperature per row across the face of each core. Such a tube-side flow pattern is uncommon in AC condenser cores, as ϵ there is not so important.

[0058] Suitable finned-tube AC condenser or evaporator cores, though generally without the most optimum tube-side flow routing, are readily available for efficient heat transfers at power levels from about a hundred watts to tens of kilowatts, and heat transfers of hundreds of megawatts can be handled just as cost effectively by paralleling tens of thousands of suitable AC cores. AC condenser cores are available at low cost because efficient production methods have been so highly optimized from the competitive pressures of high-volume manufacturing over the past four decades. Accommodating high shell-side pressures is straightforward—one simply places the assembly in a large pressure vessel with suitable baffles, as seen in U.S. Pat. No. 4,676,305, for example, and addressed later in more detail. Although AC condenser cores are usually intended for operation near 310 K, they are sometimes constructed using copper tubing with aluminum or copper fins brazed on using a filler material having liquidus near 870 K. It is also not too uncommon to use 90Cu-10Ni alloy C706 for the tubing with copper fins. In larger sizes these cores typically use tubing of 9 to 13 mm diameter, and the fin pitch (center-to-center spacing) is often under 2 mm. Fin length in the direction of air flow is typically

~25 mm per row, though sometimes up to 80 mm per row. Fin pitch in the FL recuperator up to 8 mm may be desired if the shell-side fluid is a very viscous liquid, such as an oil just above its pour point.

[0059] Only minor modifications of available cores are needed to permit operation to about 700 K at limited pressures with non-oxidizing clean gases. Moreover, operation to 900 K in many non-oxidizing conditions is possible by simply changing to an alumina-dispersion-strengthened copper such as C15720 (0.4% Al_2O_3 , bal Cu) for the fins and to the common 70Cu-30Ni alloy C715 for the tubing (~70 MPa yield strength at ~900 K for C715, compared to ~750 K for alloy C706).

[0060] The benefits of this approach may not be immediately clear to those accustomed to evaluating heat transfer primarily on the basis of surface area, as (A) changing from a conventional shell-and-tube exchanger to a typical AC condenser core may increase the shell-side surface area per volume by only a factor of 5 to 10 (from ~200 m^2/m^3 to 1000 or perhaps even 2000 m^2/m^3), (B) the tube-side "compactness ratio" may decrease by a factor of 2 or more, and (C) the heat has to be transferred twice. What may be overlooked is that the shell-side heat transfer coefficient, h_s , W/m^2-K , will also typically increase by a factor of 5 to 10 because the passage thicknesses are decreased, so the shell-side total benefit can be a factor of 25 to 100. By selection of an optimum HTL and flow velocity, the tube-side h_t can easily be made over 30 times (possibly even more than 200 times) that of most gases—usually without adding tube-side turbulators. Hence, the novel compound-exchanger can permit an order of magnitude improvement in compactness compared to shell-and-tube exchangers for gas-gas exchange (for comparable powers, flow rates, ϵ , and pumping losses) even though the heat has to be transferred twice.

[0061] The increased complexity associated with compound recuperators using a liquid intermediary would not be justified below some size threshold. That cutoff is dependent on many variables, including desired ϵ , temperatures, gas compositions, the importance of mass reduction, cleanliness of the gas streams, and gas pressure differences. It will also depend on availability of appropriate finned-tube cores for the relevant conditions, a factor that is likely to change markedly over time. Even today, it seems that compound recuperators would be preferred for many cases with non-oxidizing gases if ϵ above 70% is desired at (A) temperatures below 700 K, (B) exchange power levels above 20 kW, and (C) mean gas pressures above 0.05 MPa. Suitable cores for competitive compound exchangers for a much wider range of conditions should become available.

[0062] A few more comments are useful to help elucidate the value and hence inventiveness of the instant invention. The shell-side thermal specific conductance, W/kgK , under the typical shell-side flow conditions (largely laminar) will be inverse with the square of the pitch; but the mass will be nearly independent of the pitch for a given core volume. Clearly, as materials become steadily more expensive, there will be a strong incentive to minimize the pitch to permit ever higher heat transfer per exchanger mass. Of course, the shell-side pressure drop will increase inversely with the pitch for a given flow velocity. However, most applications will be with shell-side pressure well above 0.2 MPa, and the shell-side pumping power losses will often be inverse with the square of the gas density. Hence, smaller fin pitch than is generally seen in AC condenser cores will often be optimum, as long as the

shell-side flow-section area A_s (the frontal section area, not A_x) is kept large and the flow path length is kept short, as discussed later in more detail.

[0063] Minimum channel thickness in most prior-art, compact, high-effectiveness exchangers is ultimately limited by the need to establish highly uniform flow. Hence, manufacturing tolerances limit minimum spacing. Channel thickness tolerance is not as critical in the instant invention because flow mixing can readily occur between successive thermally isolated cores.

[0064] Current AC condenser practice (~2 mm fin pitch) is probably close to optimum in the compound exchanger for mean gas pressures of ~0.3 MPa, mean k_f of ~0.04 W/m-K, and ϵ of 75-90%. The fin pitch can often be reduced (for further reductions in exchanger mass and cost) at higher gas pressures or low temperatures. However, there are limits, as the fin thickness must be sufficient to provide the needed thermal conduction and stiffness, and corrosion lifetime may be an issue in some cases. A strong advantage of the liquid-loop compound exchanger compared to regenerators is that the gas-passage thickness of the high-pressure gas stream may readily be made much less than that for the low-pressure gas stream, as desired for maximum performance.

[0065] It is not uncommon in AC condensers for the tubes to have internal features such as ribs, fins, or undulations to increase h_L , though this adds to tubing cost and increases stress concentrations. Such surface enhancement is mostly beneficial in the initial portion of a condenser where no condensation is occurring (the tube-side vapor is still superheated) and in the final portion (subcooling) where the liquid velocities are very low. Surface enhancements are much less beneficial in the compound recuperator because the tube-side flow is liquid-only, of essentially constant velocity, which may be better optimized.

[0066] Heat-Transfer Liquids (HTLs). The primary requirements in the HTL are chemical stability at the relevant conditions, low viscosity, low vapor pressure, high thermal conductivity, fairly low cost, low health hazard, and high autoignition temperature (AIT). It is also beneficial to have freezing point above the minimum start-up temperature, though thaw-out measures can be implemented. The AIT is also of minor importance, as inert or reducing-gas pressurization over the HTL would normally be incorporated; but it is still of some concern, should liquid leaks develop. Water,

organic fluids, molten alloys, or molten salts will normally be selected, based mostly on the temperature range. Table 1 presents some pertinent data, some of which are estimates, on some HTLs at 500 K. The column labeled "Risks" gives a single, overall indication of the three hazards normally considered—health, flammability, and reactivity.

[0067] The (turbulent-flow) tube-side heat transfer coefficient may be calculated by,

$$h_L = B_1 G^{0.8} k_f^{0.6} (C_p/\mu)^{0.4} d^{-1.8} \tag{3}$$

where μ is the dynamic viscosity (cP, centipoise, which is identical to 1 mPa-s, or 0.001 kg/m-s) and B_1 is a dimensioned factor that is nearly constant over a wide range of conditions but varies with surface features and other exchanger design details. (Note: a fluid with $\mu=1$ cP and $\rho=1000$ kg/m³ has kinematic viscosity, μ/ρ , of 1 cSt, centistokes.) Mew simple manipulations and calculations are useful:

$$G^{0.8} = B_2 (\rho v)_{0.8} d^{1.6} \tag{4}$$

$$h_L = B (\rho v)^{0.8} k_f^{0.6} (C_p/\mu)^{0.4} d^{-0.2} \tag{5}$$

$$F_H = \rho^{0.8} k_f^{0.6} (C_p/\mu)^{0.4} \tag{6}$$

$$h_L = B v^{0.8} F_H d^{-0.2} \tag{7}$$

where the B's are dimensioned constants, and F_H is a convection, composite fluid property. A typical magnitude of B at a Reynolds number of 10,000 to 20,000 inside smooth tubes is ~5.6, assuming the parameters are in the units shown above. For 40 wt engine oil at 500 K, for $v=10$ m/s in tubes of 0.0077 m ID (Re \square 15,000), this gives $h_L \square$ 19000 W/m²-K. For comparison, FP Incropera gives a representative value of overall h_f for air in cross-flow with water inside finned tubes as ~35 W/m²-K, and maximum overall h_f of 6000 W/m²-K for steam condensers.

[0068] From eq. 7 and the above example, it might appear that one simply needs to increase the HTL flow velocity to make h_L very large compared to mean shell-side heat-transfer coefficient h_s (as desired for economic optimization), but of course that consumes power—which increases almost as the cube of v . The pumping power also increases with increasing ρ , μ , and flow length. Considering this, a better HTL figure of merit (composite fluid property) for its selection than the above F_H is the following F_M :

TABLE 1

HTL Properties at 500 K											
Name	pour point, K	n.b.p. K	AIT, K	ρ , kg/m ³	C_p , kJ/kg K	μ , cP	k_f , W/m-K	Risks	F_H	F_M	F_D kDt
acetone	185	329	738	411	3.44	0.05	0.08	2	146	1430	2200
ethanol	200	352	636	475	3.43	0.06	0.09	1	164	1460	2400
butanol	210	380	699	581	3.78	0.094	0.10	1	179	1260	2300
water	274	373	—	835	4.57	0.11	0.646	0	743	5130	22000
toluene	190	384	808	640	2.51	0.12	0.077	2	127	357	1030
cumene	130	425	697	661	4.57	0.15	0.108	2	188	1090	2220
ethylene glycol	260	470	673	935	3.16	0.34	0.2	1	221	369	1740
1-butyl-naphthalene	260	561	800	824	2.1	0.35	0.093	2	106	269	450
Delo 100 30 wt	243	570	550	670	2.5	0.3	0.09	0	100	300	500
PAO, Delo 400 5W40	230	580	620	670	2.5	0.3	0.09	0	100	300	500
Delo 6170 40 wt	255	620	640	680	2.5	0.35	0.09	0	96	260	440
POE, Mobil 254	212	640	672	700	2.5	0.4	0.1	1	99	250	440
diocetyl phthalate	250	657	780	798	2.1	0.5	0.11	1	98	200	365
1-dodecyl-naphthalene	305	676	800	795	2.5	0.41	0.092	1	103	250	445
tri-o-cresyl phosphate	260	693	680	950	2.2	0.4	0.11	2	136	340	680

TABLE 1-continued

HTL Properties at 500 K											
Name	pour point, K	n.b.p. K	AIT, K	ρ , kg/m ³	C_p , kJ/kg K	μ , cP	k_p , W/m-K	Risks	F_H	F_M	F_D kDt
TBPP-100 phosphate	270	708	795	900	2.2	0.5	0.13	1	123	255	515
polyphenyl ether 5P4E	280	749	860	970	1.9	0.6	0.13	1	114	200	400
60NaNO ₃ —40KNO ₃	480	870	870	1950	1.4	4.5	0.45	2	166	77	270
55Bi—45Pb	400	1800	—	10000	0.15	2.7	4	2	1150	300	2220
38Pb—37Bi—25Sn	400	1900	—	9000	0.18	2.5	8	1	1770	520	5200

$$F_M = k^{0.6} (\rho C_p)^{0.8} / \mu \quad [8]$$

[0069] The combination of the need to achieve $h_{HTL} \gg h_S$ at moderate v and flow length, along with good W matching, imposes constraints on the tube diameters and the tube paralleling scheme. The HTL would usually have nearly constant velocity throughout most of the cores, so tube diameters would be nearly constant throughout. However, in cores containing several parallel tubes, it may be beneficial for them to combine at their core entrances and exits to simplify tubing inter-connections between cores. Clearly, the HTL velocities in the interconnections could be very different from the typical value in the cores.

[0070] As seen in Table 1, F_M is low for organics compared to that for water or molten alloys, but it is usually higher than that of molten salts—a concept that has previously been misunderstood. Other advantages of organics may include no freezing problems, no metal erosion, lower corrosion, lower density, lower toxicity, lower cost, lower viscosity, and simpler disposal problems. Pressurized water can be used well beyond 500 K, but exchanger costs are increased because of the very high stresses. An organic of low vapor pressure is often better, though in some applications lower-boiling fluids, such as ethanol or even acetone, could meet the specific requirements and be preferred. Note that the relative merits of the HTLs are temperature dependent.

[0071] Silicone fluids (such as Dow Corning 550, AIT of 755 K, but not suitable for long term usage above 550 K) and low-grade hydrocarbon (HC) mixtures, such as Exxon Caloria HT-43 (AIT of 627 K) have been used. Some more attractive organic fluids with n.b.p. and AIT both above 660 K, pour point below 320 K, and acceptable chemical stability and safety are: (A) polyphenyl ethers (PPEs, aerospace lubricants and diffusion-pump oils, 5-ring type 5P4E has AIT-880 K, n.b.p.=749 K, 290 K pour point, $\Delta G_f \sim 2$ kJ/g, non toxic, has been used in short-term vapor-phase lubrication up to 870 K), (B) polyol esters (POEs, most type-2 aviation turbine oils, AIT usually ~ 670 K, but AIT and n.b.p. can be over 740 K), (C) polyalphaolefins (PAOs, a major component in type 5W50 synthetic engine oil, 16 cSt at 100° C., AIT often ~ 650 K, but AIT can be ~ 700 K in heavy PAOs), (D) phosphate esters (used in aviation hydraulic fluids), (E) phenyl silicones, (F) fluorocarbons, (G) polymer esters (PEs), (H) phthalates, and (I) mixtures of the above and high-boiling alkylated polynuclear aromatics. See Table 1 for data on two alkylated polynuclear aromatics.

[0072] Highly branched alkanes are preferred to n-alkanes in engine lubrication applications, as they have much better oxidation resistance, much lower viscosity for a given boiling point, and are more resistant to dehydrogenation and cracking. The relative price of such synthetic oils, similar to PAOs, should drop substantially over the coming decade.

[0073] Inexpensive tin-lead alloys may be acceptable as an HTL at high temperatures with stainless or superalloy tubing. The solubility of iron in tin is about 0.1% at 650 K, and this may lead to excessive exchanger erosion with low-alloy steel tubing (even after the molten alloy becomes saturated with iron, as there will be some thermal gradients in the liquid). The solubility of iron in both bismuth and lead is at least an order of magnitude lower than in tin. However, alloys of more than 50% bismuth expand upon freezing (if not immediately, then after several days), and this could produce unacceptably high stresses within the exchangers. Lead-bismuth-tin alloys of relatively low tin content should be fine with some low-cost steel alloys for the tubing. The 38Pb-37Bi-25Sn alloy shown in Table 1 has an excellent balance of low iron solubility, low vapor pressure, low toxicity, high F_M , low cost, and low liquidus temperature, though perhaps lower Bi and Sn contents with increased Pb and minor additions of antimony (Sb) would give an even better balance.

[0074] Molten salts, especially mixtures of NaNO₃, KNO₃, NaNO₂, and Ca(NO₃)₂, have often been used for HTLs. Some have freezing points lower than those of some lead alloys, but their upper temperature limits are lower. For example, KNO₃ decomposes at 670 K and NaNO₃ decomposes at 650 K, though some mixtures, such as the eutectic listed in Table 1, have higher stable temperature limits. There are some security risks, as all can easily be used to make powerful explosives of limited stability. Moreover, their NEPA health ratings are usually “2, highly hazardous”, and their F_M is quite inferior to other options. When hot, they react vigorously with most pump lubricants and elastomeric seals, and they slowly attack many alloys at grain boundaries. Another complication with salts, alloys, and heavy polynuclear aromatics is that they are solid at room temperature.

[0075] The thermal conductivities of the gases expected in some emerging applications typically range from 0.04 to 0.06 W/m-K at 500 K (for CO, C₄H₁₀, air, and some H₂/CO₂ mixtures of interest), gas densities are often ~ 5 kg/m³, C_p is often 1 to 3 kJ/kg-K, and μ is typically 0.01-0.03 cP. For gases under the relevant shell-side (substantially laminar) conditions, a composite fluid property more useful than F_M for estimating the ease with which heat transfer may be achieved is

$$F_G = k(\rho C_p)^2 / \mu \quad [9]$$

A useful expression for comparing liquid and gas heat transfer fluids for similar flow geometries (same hydraulic diameters, flow lengths, etc.) is $(F_M F_G)^{0.5}$, and this suggests the heat-transfer challenges for the gases could be two to three orders of magnitude greater than for liquids for similar geometries. A simpler parameter, F_D , for comparing diverse fluids is included in Table 1 and discussed in the last section with

reference to applications for shell-side liquids. The important point here is that there is usually little need to worry about tube-side heat-transfer enhancement. This allows enormous manufacturing simplifications. The focus needs to be primarily on reducing passage thickness and increasing surface area on the shell-side.

[0076] FL Module Implementations. As noted previously, the core sets will be inside a pressure vessel sufficient for the shell-side pressure. Often, all the sets associated with the first shell-side stream (usually a gas) would be inside one pressure vessel, and those associated with the second shell-side stream would be inside a second pressure vessel. The pressure vessel with the cores it contains is referred to as a fluid-to-liquid (FL) recuperator module, and a typical embodiment is shown crudely in FIG. 3.

[0077] A typical FL recuperator module might contain 30 series-connected, thermally isolated finned-tube cores 31 (though the figure shows just 8 cores for better clarity), each having typical external dimensions of about 1 m×1 m×0.03 m. The shell-side entrance and exit ports 32, 33 are normally at the opposite ends from the tube-side entrance and exit ports, 34, 35. A typical core is better illustrated in FIG. 4, though again not likely to scale. Each 1 m×1 m core might typically have 40 parallel finned tubes 41, each of 8 mm ID and 10 mm OD, each traversing the full width, with typical center-to-center spacing of 25 mm, and tube-side entrance and exit manifolds 42, 43. FIG. 4, on the other hand, shows 20 tubes and 64 fins, which is closer to being typical for a 30 cm×30 cm core, though even there the number of fins would likely be greater than shown by a factor of 2 to 4.

[0078] If the fin thickness is 0.5 mm and the fin pitch 1.6 mm, then the example shell-side flow-section area A_S is about 0.7 m² and the tube-side flow-section area A_T is ~0.002 m². Hence, A_S is ~350 times A_T . For the typical core dimensions noted earlier (1 m×1 m×0.03 m), the mean shell-side flow length L_S is about 0.03 m per core, and the mean tube-side flow-length L_T is 1 m per core. Hence, L_T is about 30 times L_S . Note that this ratio is independent of the number of cores when they are serially connected, as both flow lengths increase by the same factor. The flow-section area ratio is also independent of the number of serially connected cores. There may be a substantial gap between adjacent cores, as depicted in FIG. 3, in the shell-side flow direction for pressure equalization across the face of the cores and some transverse mixing, but the shell-side flow is substantially axial with respect to the pressure vessel.

[0079] The tube-side HTL flow is shown in FIG. 3 as being ducted 36 from an exit manifold on one side of a core diagonally across to the entrance manifold on the next core. Note that the HTL enters all the cores on the same side and exits all the cores on the opposite side. The diagonal HTL ducting pattern is one way to improve tube-side flow homogeneity. Other measures may also be taken, and often a primary measure will be judicious selection of the diameter of the tubes 41 such that the flow velocity within them will achieve pressure drops that are large compared to the pressure drop in the manifold while simultaneously meeting the other previously noted requirements with respect to pumping power, h_r , and W_L . Support structure for the cores is not shown, though clearly some is needed. The flow-cage 37 for constraining the shell-side flow within the cores is only partially shown. For the conditions normally addressed, the shell-side volumetric flow rate will generally be relatively high (especially when compared to tube-side), so shell-side pressure drops from

inlet 32 to outlet 33 must necessarily be low (to achieve low pumping power) and differential stresses on the cage can easily be handled. The pressure vessel would preferably have a burst pressure greater than twice the mean shell-side relative pressure and generally much greater than 0.3 MPa.

[0080] One may define an HTL conductance Y_F [W] between adjacent cores as

$$Y_F = T_d W_L \quad [10]$$

where T_d is the mean temperature difference between adjacent cores. Adjacent cores are herein considered to be effectively thermally isolated if the heat conducted between cores through solid materials is less than one-third of Y_F . Such a condition is not easily met if more than 20% of the fins are continuous from one core to the adjacent core in the shell-side flow direction, but such a condition is easily met if none of the fins are continuous between adjacent cores and the tube pattern is not interleaved between adjacent cores. However, adequate thermal isolation will sometimes be possible if up to 30% of the fins are largely continuous, except for holes for transverse pressure equalization, between adjacent rows.

[0081] It is not necessary for all tube rows to be thermally isolated. A “compound core” may have several rows of finned tubes thermally coupled by continuous fins between them for improved core robustness. However, the practical effectiveness limit is strongly dependent on the total number of thermally isolated cores in series. Hence, it will often be desirable for this number to be more than 20, though there will be some cases when as few as two thermally isolated cores per FL module are sufficient. It is unlikely that a compound core would contain more than four rows of thermally coupled rows of finned tubes. In most cases, each thermally isolated core would be a single row of finned tubes, as shown in FIGS. 3 and 4.

[0082] Shell-side flow homogeneity is also essential for high ϵ , at least when the W 's are similar. In most cases, allowing for pressure equalization across the faces, as is readily achieved when none of the fins are continuous between adjacent cores, will be sufficient, as shown in FIG. 3. In the prior art, all the fins are usually continuous between adjacent rows, such as seen in the Armstrong Duralite™ Plate Fin Coils products. A minor fraction could still be continuous. In such a case, pressure equalization across the faces of thermally isolated cores can readily be achieved if holes or cut-outs are included in fins joining adjacent cores.

[0083] With series-connected cross-flow exchangers, the flow homogeneity may be further improved by inserting turbulent mixers in the gas flow streams between cores. (This obviates the benefit from the flow routing illustrated in FIG. 2, but is better than the alternative of channeling—where, because of the viscosity dependence on temperature, the shell-side velocity may become higher than mean on one side of all the cores when the shell-side gas is being heated a large amount in each core.) The use of separate, series-connected FL modules further simplifies the insertion of turbulent mixers into the shell-side stream.

[0084] FIG. 5 illustrates a portion of a core with a serpentine pattern that may be desired to better meet the HTL velocity and pressure-drop objectives in some cases. If the tube-side flow for the core of FIG. 4 were instead handled by 10 parallel tubes of 8 mm ID, each traversing the full width 5 times in a serpentine pattern with center-to-center spacing of 20 mm, the tube-side flow-section area then would be 5E-4 m². With a reasonable allowance for the bends at each end,

each tube may then need to be ~ 6 m long. In this case, L_T would be about 200 times L_S , and A_S would be ~ 1400 times A_T . As in FIG. 4, the shell-side flow in FIG. 5 is normal to the plane of these figures.

[0085] A method of arranging thermally isolated, serially connected finned tubes without manifolds between them is shown in FIG. 6. Such an arrangement may have manufacturing advantages in some cases. An option is to stack a large number of serpentine finned tubes normal to the plane of FIG. 6, with the shell-side flow as indicated. For the shell-side flow direction assumed in FIGS. 4 and 5, the fins would normally be continuous between the tubes as shown within a core. However, the fins could not be continuous between the tubes for the flow direction shown in FIG. 6 and achieve thermal isolation between these serially connected tubes. Conventional usage may not refer to such an arrangement of a single, serpentine finned tube as a "core". When a large number of the serpentine finned tubes as shown in FIG. 6 are stacked normal to the plane of the Figure, five thermally isolated planar cores are effectively formed.

[0086] As discussed earlier, it will sometimes be preferable to utilize more than one liquid loop. Hence, in some applications, there may be two or even three liquid loops servicing the cores in a single FL module. In some applications, it may be preferable to utilize separate pressure vessels for the high-temperature cores, mid-temperature cores, and low-temperature cores, and in such cases in particular a small number of thermally isolated cores per FL module may be sufficient. In larger applications, it will often be desirable to arrange modules in parallel, as it may not be optimum to manufacture modules larger than can easily be transported by truck. Note that paralleling also does not affect the ratios A_S/A_T or L_T/L_S , but the ratio A_S/L_S steadily increases with capacity in an optimum design.

[0087] For very large modules, a hexagonal arrangement of the cores as shown in FIG. 7 (depicted without the containment vessel) may be preferred, as it permits a larger ratio of A_S/L_S within practical trucking constraints. Here, the shell-side fluid flow is generally radial, and the core arrangement of FIG. 6 is assumed, though the arrangement of FIG. 4 could also be used. Similar arrangements of finned-tube cores, except square rather than hexagonal, are commonplace in the AC industry, where shell-side air flow through a condenser exhausts to atmosphere. However, the prior-art condensers (A) utilize tube-side phase change for most of the enthalpy change, (B) are not enclosed in a pressure vessel, and (C) may not include serially connected thermally isolated cores.

[0088] For the hexagonal arrangement shown in FIG. 7, the shell-side face flows are all functionally in parallel. Hence, the tube-side flows must also be functionally in parallel. In other words, all of the innermost cores would connect to the same HTL port, and all of the outermost cores would connect to the same HTL port. Obviously, pentagonal, octagonal, or other circumferential arrangements of cores could also work well. The pressure vessel would normally have its axis aligned perpendicular to the shell-side flows through the cores.

[0089] Cores of significantly different characteristics may also be combined, either in series or in parallel, with predictable results, though the analysis is more complex. Clearly, many variations in dimensions and patterns are possible, but generally A_S would be more than 100 times A_T and L_T would

be more than 10 times L_S . Such ratios appear to be well outside the prior art in multi-pass, finned-tube, shell-and-tube heat exchangers.

[0090] Core Modifications for Severe Conditions. For high performance at demanding conditions (high temperatures, oxidizing atmospheres, or large differences in pressures between the two gases), appropriate changes in choice of materials for the tubing, fins, and braze are required. The tubing material is selected primarily for yield strength at the required temperature, formability, brazability, and corrosion resistance. The fin material is selected primarily for thermal conductivity, cost, corrosion resistance, melting point, and brazability. In some cases, the fins have been pressed on rather than brazed on, but this approach is less desirable for extremes of temperature, for closely spaced thin fins, or if much vibration is likely.

[0091] Alumina-dispersion-strengthened copper, aluminum, or nickel are particularly good choices for the fins, though cobalt and alloys are also possible for high temperature fins. While most superalloys have poor thermal conductivity compared to pure metals near room temperature, some with superior oxidation and corrosion resistance, such as Haynes 214 (16Cr, 4.5Al, 3Fe, 0.2Y, bal-Ni), have fairly good thermal conductivity at high temperatures (32.4 W/m-K at 1255 K).

[0092] Some superalloys, such as Haynes 188 (38Co, 22Cr, 22Ni, 14.5W, 2Fe, 1Mn, 0.3Si, 0.1C, 0.07La), have good brazability and formability in the annealed state as well as outstanding oxidation resistance and high-temperature strength (~ 1400 K for 70 MPa yield strength in alloy 188). An alloy similar to Haynes 188 would be well suited for high-temperature exchanger tubing, though modifications to reduce cost and improve formability and brazability, particularly by reducing Co, W, and Cr, may be preferred. The tubing material can have poor thermal conductivity with little consequence on performance. If the hydrostatic pressure on the HTL(s) is maintained near the mean of the pressures of the gas streams, preferably within a factor of two of this mean, the stresses on the tubing are reduced.

[0093] Brazes compatible with the higher temperatures and materials are required. Nickel-plated dispersion-strengthened-copper fins could be brazed to such using filler BNi-7 (890° C. liquidus, 85Ni, 14Cr, 10P). Superalloy or alumina-dispersion-strengthened nickel fins could be brazed to Haynes 188 or similar tubing using BNi-5 (1135° C. liquidus, 70Ni, 19Cr, 10Si) for operation at still higher temperatures. Methods for applying chromium platings to the finned tube rows can be developed, based on the prior art.

[0094] Organic HTLs at High Temperatures. An organic HTL may be used quite satisfactorily at a much higher temperature than that for which it has normally been recommended if suitable measures are taken. First of all, it is most important that the surfaces in contact with the hot oil (tubing interiors, etc.) be catalytically deactivated with a thin layer (0.1 micron is sufficient) of coke—carbon and very heavy condensed polynuclear aromatics. Thermal (non-catalytic) reactions require much higher temperatures than catalytic, and most metallic or oxide surfaces have some catalytic activity. Secondly, since water catalyzes reactions on many metal surfaces, it is important to maintain the liquid pressure well above the maximum external gas pressure (the greater of the pressures in shell-side gas-1, gas-2, and ambient) at all times to prevent ingress of air and moisture through minute leaks.

Of course, it is important to insure that any organic HTL is initially de-gassed of dissolved O_2 and H_2O .

[0095] In general, there are four primary types of thermal reactions that will dominate for most of the heavy HCs likely to be used for a high-temperature HTL: cracking, dehydrogenation, de-isomerization, and aromatic polymerization or condensation. All but de-isomerization (conversion from a highly branched to a less branched structure) are somewhat inhibited by moderate H_2 and CH_4 concentrations within the HTL—or perhaps it is more proper to say that high H_2 and CH_4 concentrations increase the rate of the reverse of many undesired reactions.

[0096] As previously noted, a small surge tank is required for the HTL to accommodate expansion and contraction. To extend the lifetime and useable temperature limit, the gas overhead 7 in this reservoir should have an H_2 partial pressures of at least 0.01 MPa and possibly as much as 5 MPa, though excessive H_2 partial pressures will increase cracking (especially of n-alkanes) and hydrogenation of aromatics into lower-boiling cyclics. Hence, it may be desirable to also have significant methane partial pressure, possibly as much as 15 MPa, as it is less reactive. For some HTLs, such as water, glycols, phthalates, silicones, polyol esters, and polyphenyl ethers, partial pressurization with argon and perhaps N_2 may be preferred. Maintaining an excessive total pressure on the HTL increases the cost of the high-temperature cores and exacerbates problems with dynamic seals, but an HTL static pressure about 0.1 to 1 MPa above the higher of the shell-side gas pressures would normally add little to the system cost.

[0097] The concentrations of CH_4 and H_2 dissolved within the HTL are determined largely by their partial pressures and the liquid temperature in the HTL reservoir. Solubilities of H_2 in HCs (A) are generally higher for alkanes than for aromatics, (B) they increase with increasing temperature, (C) they approximate a Henry's law behavior, and (D) they decrease slowly with increasing molecular mass of the HTL. The solubility of H_2 , in moles H_2 per kg liquid per MPa, at 460 K are 0.068 and 0.044 for hexadecane ($C_{16}H_{34}$) and tetralin ($C_{10}H_{12}$) respectively, for example. Solubilities at 520 K are about 30% higher. Solubilities in very heavy oils are about half that for hexadecane. Methane solubility is much higher (by perhaps a factor of 20 at 460 K) and much less dependent on temperature. When the HTL cools during power-down, it may effervesce H_2 .

[0098] It will normally be preferable to have the liquid pumps at the low-temperature points in the loops, as shown in FIG. 1, as this simplifies problems associated with dynamic seals. It may also be preferable to have the reservoir near the low-temperature point in the loop to avoid H_2 super-saturation within the HTL at its cooler points in the loop, as super-saturation could lead to hydrogen effervescence in the cooler exchangers and reduced heat transfer. However, some level of H_2 super-saturation is usually quite stable in HCs, and this may further inhibit production of coke precursors with some HTLs. Hence, it may be preferable to have the surge tank at a higher temperature point in the loop, even though this increases its cost a little.

[0099] Even with the above measures, operating at temperatures near the upper practical limits will result in the production of reaction products, both light and heavy, that are undesirable beyond a certain level but are quite tolerable at low levels. In most cases, this will simply mean that periodic HTL changes will be required. For large installations there are other options. Cracking produces light alkenes, some of

which will be hydrogenated to light gases such as C_2H_6 , C_3H_8 , and C_4H_{10} , which are less than optimum for reservoir pressurization. An easy way to deal with such is to continually, slowly vent some pressurization gas and maintain the desired pressure with fresh gas of optimum mixture. Of course, membranes and other separations methods could be used to separate the vented gas into useful product streams if desired. Some of the alkenes will alkylate with other alkanes or aromatics to heavy HCs and coke precursors in the HTL. One way to maintain the HTL at an acceptable composition is to steadily bleed HTL from the reservoir and maintain the desired level with fresh supply. Various separations methods could be applied to the used fluid for reclamation. More examples of reaction-product separation processes are disclosed in a co-pending patent application on Dual-source Organic Rankine Cycles.

[0100] In summary, the following are required to operate with organics at high temperatures:

1. Deactivate all surfaces in contact with the hot HTL.
2. Maintain sufficient HTL pressure to prevent ingress of air and moisture through minute leaks.
3. Maintain an optimum gas mixture pressurizing the HTL.
4. Remove primary HTL reaction products before they lead to excessive coking.
5. Select a fluid with high chemical stability with optimum gas pressurization.

[0101] For the temperatures indicated in the example of FIG. 1 with appropriate gas pressurization over the HTLs, the HTL for sets A and B could be dioctyl phthalate, a PAO oil, or a POE oil. For sets C and D, a molten alloy, a molten salt, PPE-5P4E, or possibly an alkylated polynuclear aromatic could be used.

[0102] Cryogenic Applications. While some of the largest applications may be at elevated temperatures in chemical processes and power plants, there will also likely be enormous applications at cryogenic temperatures, as very high ϵ in exchange between gases is often required there. Moreover, gas viscosities (and hence pressure drops) there are often so low that it is very difficult to establish the uniform flow conditions that are essential for high ϵ . As previously noted, the use of separate, series-connected cores or FL modules allows simple insertion of turbulent mixers into the shell-side stream between modules.

[0103] For cryogenic applications, the fin pitch can be further reduced—because (A) viscous losses are much smaller, (B) the fin-metal thermal conductivity can be an order of magnitude higher, (C) the gas thermal conductivity is often much lower, (D) the HTL may have a higher F_M , and (E) corrosion is more readily controlled.

[0104] One HTL, cumene (isopropylbenzene, C_9H_{12}), is listed in Table 1 that is particularly advantageous down to 130 K, and others are suitable for lower temperatures. Propane, for example is usable down to 90 K and is easily liquefied at room temperature, as its critical temperature T_C is 370 K. For lower temperatures, gases with T_C well below 300 K are required, and this complicates start-up somewhat, as a rather large compressed-gas reservoir is needed. Oxygen ($T_C=155$ K) is an excellent HTL for the range of 60-130 K. Fluorine oxide, F_2O ($T_C=215$ K), is suitable for the 55-170 K range, and other gases can be used over other, narrow ranges. For example, H_2 ($T_C=33$ K) can be used over the 15-30 K range. However, very high pressures are required to condense these gases near the upper ends of their maximum liquid ranges, and this increases exchanger cost.

[0105] In principle, a gas could be used as the heat transfer intermediary, where the obvious choice for the 35-60 K range would be hydrogen. However, high (tube-side) h_{zL} with low pumping power cannot be achieved with a gas as the intermediary above its T_C , as its density is much too low at practical pressures. The best way to increase h_{zL} with gases is to use MMP tubing, which indeed works beautifully at very high pressures.

[0106] The minimum competitive size of the compound exchanger for cryogenic applications will be smaller than for most high-temperature applications—because mass is often much more critical and mean temperature difference between the gas streams may need to be an order of magnitude smaller. The compound exchanger seems likely to be preferred in many cryogenic recuperators down to 90 K at exchange powers above 1 kW for gas pressures below 0.5 MPa.

[0107] Compact Recuperator Variations. An advantage not yet noted for the compound exchanger is that it can greatly reduce the ducting costs in large plants where the heat generated in one process is needed in another process hundreds of meters or even tens of kilometers away. In such a case, it will sometimes be easier to achieve optimum thermal balancing—matching the gas W and temperature to those of the HTL within each module—by splitting and re-combining the HTL streams at numerous points. When streams are combined, their temperatures should be similar for minimal exergy destruction. A portion of an HTL may be split out from an intermediate point in an exchanger module to exchange energy with another process and then be re-combined at an appropriate point where the temperature is similar.

[0108] Of course, it is not uncommon to transfer heat long distances using either phase change (usually water) or liquids (including many of those mentioned earlier as good HTLs for compound recuperators). For example, Severinsky in US publication 2006/0211777 notes that it can be advantageous to transfer heat throughout a large plant using a number of different phase-change heat-transfer fluids (HTFs).

[0109] While it is important to emphasize that exergy destruction is more readily minimized by avoiding substantial phase change when there is a large temperature difference between the hot source gas and the cold source gas (so the number of HTL loops can be reduced), a minor amount of boiling and condensing may take place within the HTLs without departing from the spirit of this invention. Hence, the HTL may be referred to as an HTF, as is customary in the prior art, though in a high- ϵ recuperator the enthalpy associated with phase change would be small compared to that associated with temperature change.

[0110] The description of the shell-side fluids as “clean gases” in earlier discussions requires further clarification. It is anticipated that in many cases the amount of condensation, acid formation, ice formation, corrosion, and particulates will be minor, though such are not precluded. When fouling mechanisms are negligible, the fin pitch may be reduced for improved compactness. However, the FL recuperator will still be advantageous in many applications where these mechanisms are substantial—though perhaps not where they are strongly dominant.

[0111] Fouling will often be significant in only one of the gas streams, and often only at either the hot or cold end of that stream. A strong advantage of the compound recuperator is that it may readily permit individual modules to be switched off-line for rejuvenation (defrosting, cleaning, re-plating, etc.) while a fresh module is put into service. In some case, the

fouled module may need to be shipped back to the factory for service, but often it will simply need to be drained, defrosted, burned out, or solvent washed. In many cases, it will simply be necessary to orient those modules in which significant condensation occurs so that the condensate readily drains while in use—as for example the draining of moisture from the common AC evaporator on a humid day. The compound exchanger will often permit a dramatic reduction in the number of replacement exchanger modules that will need to be kept on hand in a large process plant.

[0112] Large applications are also anticipated where the shell-side fluids are viscous organic liquids, since such exchanges also benefit from the very short flow passages that can more easily be obtained in the inventive module. While the benefits may be greatest with oils of high viscosity, even moderate-viscosity oils, such as 1,3-diphenylpropane at 310 K, where $\mu=4.4$ cP, $k_f=0.12$ W/m-K, $\rho=968$ kg/m³, and $C_p=2$ kJ/kg-K, would benefit when high effectiveness is needed, especially if effervescence is also present in one of the streams. In such a case, a phase separator or flash drum can be inserted between modules or even between cores to separate the evolved shell-side gas so the fluid’s volumetric flow rate (and hence velocity) remains low—to limit viscous losses.

[0113] A composite fluid property that is dimensionally much simpler than $(F_M F_G)^{0.5}$ and nearly as valid for comparing diverse fluids for similar flow geometries is

$$F_D = k_f \rho C_p / \mu \quad [11]$$

The HTL in Table 1 having the lowest F_D (i.e., least desirability) at 500 K is (again) the salt, where $F_D=2.7E5$ J²/(s-m⁴-K²-cP) in these mixed reduced units, which herein will be abbreviated Dt (for Doty). (In SI units, 1 Dt=1000 J²/(kg-m³-K².) For comparison (again at 500 K), F_D is seen to be ~440 kDt for 40 wt engine oil and 22 MDt for water.

[0114] In contrast, the shell-side fluids have lower F_D . A typical value for the gas conditions indicated earlier (500 K, 5 kg/m³, 0.05 W/m-K, etc.) would be ~25 kDt. Some liquids for which high-performance heat recovery will be needed have F_D well below those of a preferred HTL, and in such cases, a compound recuperator can be advantageous, particularly if the temperature permits the use of a tube-side HTL of very high F_D , such as water or a molten alloy.

[0115] For diphenylmethane at 310 K for example, F_D is ~100 kDt, and for 1,3-diphenylpropane F_D is 52 kDt. For heavy oils, F_D can be an order of magnitude smaller yet, even at temperatures where substantial heat recuperation may be needed in some situations.

[0116] The FL recuperator will be useful for heat recovery in many fluids where F_D is less than 200 kDt at the operating conditions, which generally implies $\mu \geq 1$ cP for organic liquids. When the shell-side fluid has rather high F_D (as for some low-viscosity liquids and gases at very high pressures), a tube-side HTF would be needed with very high F_D , such as water or a molten alloy. However, a tube-side HTF with F_D as low as 200 kDt would be satisfactory when operating with shell-side fluids of rather low F_D . Preferably, the tube-side fluid would have F_D more than 10 times that of the shell-side fluids (which of course can be very different, and at very different conditions).

[0117] Although this invention has been described herein with reference to specific embodiments, it will be recognized that changes and modifications may be made without departing from the spirit of the present invention. All such modifi-

cations and changes are intended to be included within the scope of the following claims.

I claim:

1. A fluid-liquid (FL) recuperator for heat exchange between a shell-side fluid stream of mean flow-section area A_S and a tube-side heat-transfer liquid (HTL) of mean flow-section area A_T , said recuperator comprising

a plurality of thermally isolated serially connected adjacent exchanger cores, wherein cores are considered thermally isolated if fewer than 30% of the fins are substantially continuous in the shell-side flow direction between adjacent cores and the tube pattern is not interleaved between adjacent cores,

said core further characterized as comprising at least one substantially planar row of finned tubes for transfer of heat between a shell-side stream of mean flow length L_S and an HTL of mean tube-side flow length L_T ,

said core further characterized in that the length of the fins per row in the shell-side flow direction is less than 80 mm, the fin pitch is less than 8 mm, A_S is greater than $100A_T$, and L_T is greater than $10L_S$,

a cylindrical pressure vessel having burst pressure greater than 0.3 MPa enclosing said cores, aligned such that its axis is substantially parallel to the shell-side flow, and having shell-side fluid-flow ports near its opposite ends, means for directing the shell-side flow substantially through said cores,

said FL recuperator further characterized in that the fluid flow connections between said cores are such as to achieve a substantially counterflow exchange between the shell-side stream and the HTL.

2. The FL recuperator of **1** in which said cores are further characterized in that the length of the fins per row in the shell-side flow direction is less than 40 mm, the fin pitch is less than 4 mm, A_S is greater than $200A_T$, and L_T is greater than $20L_S$.

3. The FL recuperator of **1** further characterized as including a transverse passage between thermally isolated cores to equilibrate shell-side pressures across the faces of said cores.

4. The recuperator of **1** further characterized as utilizing alumina-dispersion-strengthened-metal fins brazed perpendicularly onto alloy tubes of yield strength greater than 70 MPa at 750 K.

5. The recuperator of **1** further characterized as utilizing alumina-dispersion-strengthened-nickel fins brazed perpendicularly onto superalloy tubes of yield strength greater than 70 MPa at 1300 K.

6. The FL recuperator of **1** in which said tubes are further characterized as having a substantially smooth inner surface with a coating for catalytic deactivation.

7. The FL recuperator of **1** further characterized as comprising a minimum of five thermally isolated cores.

8. The FL recuperator of **1** further characterized as including multiple pairs of ports for multiple liquid loops.

9. A fluid-liquid (FL) recuperator for heat exchange between a shell-side fluid stream of mean flow-section area A_S and a tube-side heat-transfer liquid (HTL) of mean flow-section area A_T , said recuperator comprising

a circumferential arrangement of a plurality of thermally isolated serially connected adjacent exchanger cores, wherein cores are considered thermally isolated if fewer than 30% of the fins are continuous between adjacent cores in the shell-side flow direction and the tube pattern is not interleaved between adjacent cores,

said core further characterized as comprising a substantially planar row of finned tubes for transfer of heat between a shell-side stream of mean flow length L_S and an HTL of mean tube-side flow length L_T ,

said core further characterized in that the length of the fins per row in the shell-side flow direction is less than 80 mm, the fin pitch is less than 8 mm, A_S is greater than $100A_T$, and L_T is greater than $10L_S$,

a cylindrical pressure vessel having burst pressure greater than 0.3 MPa enclosing said cores and aligned such that its axis is substantially perpendicular to the shell-side flow through said cores, said shell-side flow being substantially radial with respect to said pressure vessel,

means for directing the shell-side flow substantially through said cores,

said FL recuperator further characterized in that the fluid flow connections between said cores are such as to achieve a substantially counterflow exchange between the shell-side stream and the HTL.

10. The FL recuperator of **9** further characterized as including transverse passages between thermally isolated cores to equilibrate shell-side pressures across the faces of said cores.

11. A method for heat exchange between a first shell-side fluid stream at mean pressure p_1 and a second shell-side fluid stream at mean pressure p_2 , said method using

a first set of serially connected thermally isolated cross-flow exchanger cores for transfer of heat between an intermediary tube-side heat transfer fluid (HTF) and the first shell-side stream,

a second set of serially connected thermally isolated cross-flow exchanger cores for transfer of heat between the HTF and the second shell-side stream,

said HTF characterized as being substantially liquid phase throughout all cores and having critical temperature not less than 370 K,

wherein a core is characterized as comprising at least one row of finned tubes,

said finned tubes are further characterized in that the length of the tube fins per row in the shell-side flow direction is typically less than 80 mm and the fin pitch is typically less than 8 mm.

12. The method of **11** further characterized as having more than 4 thermally isolated cores exchanging with each shell-side stream and having effectiveness ϵ greater than 60% at design operating conditions.

13. The method of **11** in which said shell-side fluids are further characterized as selected from the set comprised of organic liquids having viscosity greater than 1 cP at 310 K and gases at pressure greater than 0.05 MPa.

14. The method of **11** where said HTF is further characterized as having flow rate G_L kg/s, specific heat C_{PL} J/kg-K,

and $W_L = G_L C_{PL}$,

said first shell-side fluid has flow rate G_1 , specific heat C_{P1} , and $W_1 = G_1 C_{P1}$,

said second shell-side fluid has flow rate G_2 , specific heat C_{P2} , and $W_2 = G_2 C_{P2}$,

said geometric mean shell-side conditions defined by $W_S = (W_1 W_2)^{0.5}$,

said tube-side conditions further characterized in that $W_L > 0.7 W_S$ and $W_L < 1.4 W_S$.

15. The method of **11** further characterized in that said HTF is selected from the set comprised of water, organics, molten

alloys; and molten salts and is further characterized as having F_D greater than $2E5 \text{ J}^2/(\text{s}\cdot\text{m}^4\cdot\text{K}^2\cdot\text{cP})$ at the mean operating temperature, where

$$F_D = k_t \rho C_p / \mu,$$

where k_t is in $\text{W}/\text{m}\cdot\text{K}$, ρC_p is in $\text{J}/\text{m}^3\cdot\text{K}$, and μ is in cP .

16. The method of **15** further characterized in that said tube-side HTF has F_D greater than the lesser of the F_D of either of the shell-side streams by more than a factor of 10 at mean operating conditions.

17. The method of **15** further characterized in that each of said shell-side streams has F_D less than $2E5 \text{ J}^2/(\text{s}\cdot\text{m}^4\cdot\text{K}^2\cdot\text{cP})$ at the operating conditions.

18. The method of **11** further characterized as including a plurality of liquid pumps and liquid reservoirs for circulation of a plurality of HTFs.

19. The method of **11** in which said HTF is further characterized as substantially selected from the set comprised of polyphenyl ethers, polyol esters, polyalphaolefins, phosphate esters, phthalates, silicones, fluorocarbons, polymer esters, organic liquid mixtures that include alkylated polynuclear aromatics, and engine oils.

20. The method of **19** further characterized as including a liquid reservoir with overhead gas space, said gas having H_2 partial pressure greater than 0.01 MPa, O_2 partial pressure less than 1 kPa, H_2O partial pressure less than 10 kPa, and total pressure greater than 0.15 MPa.

21. The method of **11** in which said HTF is further characterized as substantially comprised of a lead-bismuth-tin alloy.

22. The method of **11** further characterized in that the mean pressure in said HTF is between 50% and 200% of the mean of p_1 and p_2 .

23. The method of **11** wherein one of said shell-side fluids is further characterized as an organic solvent containing a dissolved gas that effervesces when the fluid is heated, and means are included between cores for separating the effervesced gas from the liquid.

24. The method of **11** wherein one of said shell-side fluids is further characterized as a gas containing a vapor that condenses when the fluid is cooled, with means for draining the condensed liquid from a core.

25. The method of **11** in which said HTF is further characterized as an organic liquid, and means are included for separation of reaction products from said HTF.

26. The method of **11** further characterized in that p_2 is greater than $3p_1$ and the typical fin pitch in said second set of cores is less than 70% of the typical fin pitch in said first set of cores.

27. The method of **11** further characterized as including transverse passages between thermally isolated cores to equilibrate shell-side pressures across the faces of said cores, wherein cores are considered thermally isolated if fewer than 30% of the fins are continuous between adjacent cores in the shell-side flow direction and the tube pattern is not interleaved between adjacent cores.

* * * * *